

HYBRID MODELING AND CONTROL OF A DIRECT INJECTION STRATIFIED CHARGE ENGINE

Alberto Bemporad and Nicolò Giorgetti
Dip. Ingegneria dell'Informazione
University of Siena
Email: {bemporad,giorgetti}@dii.unisi.it

Ilya Kolmanovsky and Davor Hrovat
P/T Control Systems Department
Ford Research Laboratory
Dearborn, Michigan 48124
Email: {ikolmano,dhrovat}@ford.com

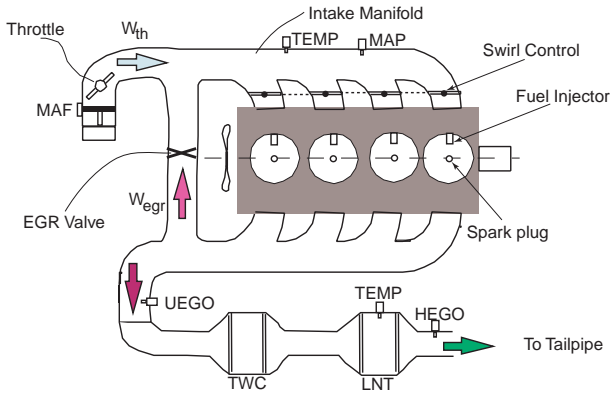

Figure 1. Direct Injection Stratified Charge (DISC) Engine.

ABSTRACT

This paper illustrates the application of hybrid modeling and optimal control to the problem of air-to-fuel ratio and torque control in advanced technology gasoline direct injection stratified charge (DISC) engines. DISC engines have two discrete modes of operation, stratified and homogeneous, and their dynamic behavior can be easily captured by a hybrid model. We show that the design flow (hybrid modeling and controller synthesis) is simple in terms of problem setup and tuning, provides good closed-loop performance, and leads to a control law that can be implemented on automotive hardware as a piecewise affine function of the measured and estimated quantities.

1 Introduction

To meet stricter emission regulations and growing customer drivability and fuel economy requirements, modern automotive engines and their control strategies are becoming more complex. In particular, they increasingly rely on multiple operating modes to provide flexibility in meeting the diverse performance requirements, and to accommodate changes in priorities of control objectives during engine operation.

Discrete operating modes occur naturally in engines that use discrete actuators. Examples include variable displacement engines where the number of active cylinders can be changed, variable compression ratio engines where compression ratio can be changed and certain variable valve event systems where the number of activated intake or exhaust valves, valve timing or valve lift can be changed between two or more discrete settings. In these situations, the engine management system has to be designed so that it can not only control the “continuous” actuators (such as throttle, fueling rate and spark timing), but at the same time so that it can optimally select an appropriate operating mode. Hybrid modeling and optimal control can thus become critical tools in developing control systems for such engines.

In this paper, these issues are considered in detail for Direct Injection Stratified Charge (DISC) engines, see Figure 1. These spark ignited engines hold a significant promise for fuel economy improvements. In particular, their capability of extended lean operation provides significant pumping loss reduction and thermodynamic efficiency improvements.

In DISC engines, the combustion regime can be changed from stratified charge (non-homogeneous fuel-air mixture across the cylinder) to homogeneous charge (homogeneous fuel-air mixture across the cylinder), by changing the fuel injection timing from

late to early, respectively. If the fuel injection timing is late (in the compression stroke), the time available for fuel to mix with air in the cylinder is short and a stratified air-fuel mixture (i.e., non-homogeneous across the cylinder) forms. In the stratified regime, the combustion can proceed in a region near the spark plug while the overall air-to-fuel ratio can be extremely lean at the same time (up to 50:1). If the fuel injection timing is early (in the intake stroke), the fuel has sufficient time to mix well with air, to form a homogeneous air-fuel mixture across the cylinder. In the homogeneous combustion regime the operation with lean air-to-fuel ratio is possible but the range is limited to air-to-fuel ratios up to about 21:1 due to engine roughness and misfire constraints. Lean operation is beneficial for fuel economy because higher intake manifold pressure at the same torque output results in lower pumping losses. The optimization of fuel economy and emissions suggests that the stratified combustion regime be used for low and part engine speeds and loads while at higher engine speeds and loads the homogeneous combustion regime is advantageous. The torque and emission characteristics of the engine are very different for the two combustion regimes (Sun *et al.*, 1999).

The control objectives for DISC engines include tracking of the air-to-fuel ratio and of the torque set-points, but the priority of these set-points may change during the actual engine operation. When the engine is operating with a lean air-to-fuel ratio, meeting the driver's torque demand becomes the most important priority. Specifically, the control system must ensure that the engine brake torque τ follows closely the demanded engine torque, τ_d , both in transients and in steady-state. At the same time, transient excursions of the air-to-fuel ratio away from the set-point are acceptable as long as the *constraints* on the range of the air-to-fuel ratio and spark timing are not violated. The air-to-fuel ratio, λ , must, of course, match the desired value, λ_d , in steady-state. This mode of functioning is referred to as the *torque control* mode and it is utilized not only during the nominal lean operation but also during the transitions between the nominal lean operation and Lean NOx Trap purge operation. At higher loads or during the actual Lean NOx Trap purge, the engine may be operated in a different, *air-to-fuel ratio control* mode. In this mode the main emphasis is put on accurate air-to-fuel ratio tracking, e.g., for efficient Three-Way-Catalyst (TWC) operation or optimal Lean NOx Trap purging.

Thus the control design for DISC engines is complicated by *hybrid* nature of these engines which is due to two possible combustion regimes (stratified or homogeneous) and two control modes (torque control or air-to-fuel ratio control). Additionally, pointwise-in-time state and control constraints on the ranges of air-to-fuel ratio and spark timing need to be enforced both in transients and in steady-state so that engine operation can be maintained without excessive engine roughness, misfires and emissions.

In this paper we utilize a hybrid modeling, and a recently developed hybrid receding horizon optimal control framework to design an effective control system for DISC engines that manages simultaneously and optimally “continuous” (throttle, fuel, spark) and “dis-

crete” (combustion regime) actuators so that the transient response of the engine is shaped as desired. In particular, we model the DISC engine according to the framework introduced in (Bemporad and Morari, 1999), and synthesize an optimal control law for the resulting hybrid model (Bemporad *et al.*, 2000). We show, through simulations on a nonlinear model of the engine, that good performance is achieved. The resulting optimal controller consists of a piecewise affine function of the measured and estimated quantities, and can be easily implemented.

The paper is organized as follows. A mathematical model of the DISC engine is described in Section 2. The hybrid modeling and the optimal control strategy are discussed in Sections 3 and 4, respectively. In Section 5 we report the simulation results. The implementation of the control law in the explicit piecewise affine form, suitable for standard automotive hardware, is discussed in Section 6. Finally, Section 7 contains some concluding remarks.

2 DISC Engine Model

In this paper we consider a control-oriented, mean-value DISC engine model developed and validated in (Sun *et al.*, 1999; Kolmanovsky *et al.*, 2000). To simplify the exposition of the main ideas here we omit the treatment of external exhaust gas recirculation (EGR).

The intake manifold pressure and mass flow rates into the intake manifold are related by the following equation

$$\dot{p}_m = c_m (W_{th} - W_{cyl}) = c_m (W_{th} - k_{cyl} \cdot p_m), \quad (1)$$

where p_m is the intake manifold pressure; $c_m = \frac{RT_m}{V_m}$, T_m is the intake temperature, R is the difference of specific heats for air, and V_m is the intake manifold volume; W_{th} is the mass flow rate through the electronic throttle which is a nonlinear function of p_m obtained from a standard orifice flow representation; $W_{cyl} = k_{cyl} p_m$ is the mass flow rate of air into the engine cylinders, and k_{cyl} is a pumping coefficient that depends on the engine speed and intake temperature. This equation represents the differentiated ideal gas law under isothermal conditions.

The in-cylinder air-to-fuel ratio is defined as

$$\lambda = \frac{W_{cyl}}{W_f} = \frac{k_{cyl} p_m}{W_f}, \quad (2)$$

where W_f is the mass flow rate of fuel into the engine cylinders.

The engine brake torque is a sum of three components

$$\tau = \tau_{mfr} + \tau_{pump} + \tau_{ind}, \quad (3)$$

where τ_{mfr} and τ_{pump} are the mechanical friction torque and the pumping torque, respectively, and are modelled by affine functions

of p_m which also depend on the engine speed. τ_{ind} is the indicated torque,

$$\tau_{ind} = (\theta_a + \theta_b(\delta - \delta_{mbt})^2)W_f, \quad (4)$$

$\theta_a, \theta_b, \delta_{mbt}$ are affine functions of λ that depend on the spark timing δ and the combustion regime ρ . In particular, $\rho = 0$ corresponds to the stratified regime, while $\rho = 1$ to the homogeneous regime. Such a binary nature of ρ is the main source of ‘‘hybridness’’ in the DISC model.

The goal of this paper is to design a control law that generates the inputs $W_{th}, W_f, \delta, \rho$ as a function of the measurements or estimates of p_m, τ and λ so that the latter follow some desired reference trajectories $p_{mref}, \lambda_{ref}, \tau_{ref}$ and constraints imposed by engine feasible operating region are satisfied. Because of the presence of the binary input ρ , we will solve the control problem within a hybrid systems framework. To this end, we need a hybrid model of the DISC engine.

3 Hybrid Model for Control

Hybrid systems provide a unified framework for describing processes evolving according to continuous dynamics, discrete dynamics, and logic rules (Antsaklis, 2000; Branicky, 1995; Branicky and Mitter, 1995; Gokbayrak and Cassandras, 1999; Hedlund and Rantzer, 1999; Lygeros *et al.*, 1999; Pantelides *et al.*, 2000). The interest in hybrid systems is mainly motivated by the large variety of practical situations where physical processes interact with digital controllers, as for instance in embedded systems. Several modeling formalisms have been developed to describe hybrid systems (Heemels *et al.*, 2001; Labinaz *et al.*, 1996), among them the class of Mixed Logical Dynamical (MLD) systems (Bemporad and Morari, 1999). Examples of real-world applications that can be naturally modeled within the MLD framework are reported in (Bemporad *et al.*, 2001; Borrelli *et al.*, 2001; Bemporad and Morari, 1999). The language HYSDEL (HYbrid Systems Description Language) was developed in (Torrise *et al.*, 2000) to obtain MLD models from of a high level textual description of the hybrid dynamics, and will be exemplified in this paper.

The model obtained in Section 2 is transformed into an equivalent discrete-time hybrid model through the following steps:

1. **Linearization and time-discretization.** We define two operating points, one for the stratified regime and the other for the homogeneous regime, and linearize model (1), (2), (3) around such points. The resulting linear model is then discretized in time using exact sampling. Denoting by T the sampling time and by t the current time step, Equation (1) becomes

$$p_m(t+1) = e^{-Tc_m k_{cyl}} p_m(t) + \frac{1}{k_{cyl}} (1 - e^{-Tc_m k_{cyl}}) W_{th}(t), \quad (5)$$

while Equations (2) and (3) become

$$\lambda(t) = \lambda^d(\rho) + \frac{k_{cyl}}{W_f^d(\rho)} p_m(t) - \frac{k_{cyl} p_m^d(\rho)}{W_f^d(\rho)^2} W_f(t),$$

and

$$\begin{aligned} \tau(t) = & \tau^d(\rho) + \left. \frac{\partial \tau}{\partial p_m} \right|_{d(\rho)} \tilde{p}_m + \left. \frac{\partial \tau}{\partial W_f} \right|_{d(\rho)} \tilde{W}_f + \left. \frac{\partial \tau}{\partial \delta} \right|_{d(\rho)} \tilde{\delta} \\ & + \left. \frac{\partial \tau}{\partial \lambda} \right|_{d(\rho)} \tilde{\lambda}, \end{aligned}$$

where $[\cdot]^d$ denotes the operating point for variable $[\cdot]$, $[\tilde{\cdot}] = [\cdot] - [\cdot]^d$, (ρ) denotes the dependence on the regime ρ of the engine, and the notation $\left. \cdot \right|_{d(\rho)}$ denotes the value at $p_m^d(\rho), W_f^d(\rho), \lambda^d(\rho), \delta^d(\rho)$.

The model is augmented by two integrators to obtain zero offsets in steady-state

$$\varepsilon_\tau(t+1) = \varepsilon_\tau(t) + T \cdot (\tau - \tau_{ref}) \quad (6a)$$

$$\varepsilon_\lambda(t+1) = \varepsilon_\lambda(t) + T \cdot (\lambda - \lambda_{ref}), \quad (6b)$$

where $[\cdot]_{ref}$ represents the reference value for variable $[\cdot]$. In particular, this augmentation of the integrators ensured zero offsets in τ and λ from τ_{ref} and λ_{ref} on the nonlinear simulation model, given some model mismatch between it and the MLD design model.

In summary, the hybrid model that will be used later for control design has $p_m, \lambda, \tau, \varepsilon_\tau, \varepsilon_\lambda$ as states, $W_{th}, W_f, \delta, \rho$ as manipulated variables. The desired throttle position is backtracked from the orifice throttle flow representation, once W_{th} is known.

2. **Constraints.** Constraints are added to guarantee the correct operation of the engine:

- a. A constraint on the air-to-fuel ratio. It is due to engine roughness and misfiring at air-to-fuel ratios that are too lean, and increases in hydrocarbon and smoke emissions at air-to-fuel ratios that are too rich. The constraint takes the form

$$\lambda_{\min}(\rho) \leq \lambda(t) \leq \lambda_{\max}(\rho). \quad (7)$$

Note that the limits $\lambda_{\min}(\rho), \lambda_{\max}(\rho)$ depend on the combustion regime ρ .

- b. A constraint on the mass flow rate of the electronic throttle, $0 \leq W_{th} \leq K$ where K is assumed to be a constant in the controller design phase¹. In the simulation phase, the actual representation of W_{th} as a function of throttle position and intake pressure was used, and throttle position was saturated between its maximum and minimum limits.
- c. A constraint on the spark timing $\delta(t)$ to avoid excessive engine roughness:

$$0 \leq \delta(t) \leq \delta_{mbt}(\lambda, \rho), \quad (8)$$

where $\delta_{mbt}(\lambda, \rho)$ is modeled as a piecewise affine function of λ and ρ , i.e., $\delta_{mbt}(\lambda, \rho) = k_1\lambda + k_2\rho + k_3$.

To avoid infeasibilities due to the mismatch between the hybrid model and the real engine, constraints (7)–(8) are treated as soft constraints, namely $\lambda_{\min}(\rho) - s \leq \lambda(t) \leq \lambda_{\max}(\rho) + s$, $0 \leq \delta(t) \leq \delta_{mbt}(\lambda, \rho) + s$, with $s \geq 0$. The constraints on W_{th} do not need to be softened, as W_{th} is a decision variable.

The above dynamic equations and constraints are modeled in HYSDEL. The corresponding list is reported in the Appendix. The HYSDEL compiler translates difference equations and constraints into the MLD system

$$x(t+1) = Ax(t) + B_1u(t) + B_2\gamma(t) + B_3z(t), \quad (9a)$$

$$y(t) = Cx(t) + D_1u(t) + D_2\gamma(t) + D_3z(t), \quad (9b)$$

$$E_2\gamma(t) + E_3z(t) \leq E_1u(t) + E_4x(t) + E_5. \quad (9c)$$

In our case, $x = y = [p_m \ \lambda \ \tau \ \varepsilon_\tau \ \varepsilon_\lambda] \in \mathbb{R}^5$ and $u = [W_{th} \ W_f \ \delta \ \tau_{ref} \ \lambda_{ref} \ s \ \rho] \in \mathbb{R}^6 \times \{0, 1\}$, where W_{th} , W_f , δ , ρ are the manipulated variables, τ_{ref} , λ_{ref} are the reference signals entering the integrators in (6), and s is the slack variable required for softening the state constraints. In general, γ and z , are, respectively, a binary and a real auxiliary vector whose value is determined uniquely by the inequalities (9c) once $x(t)$ and $u(t)$ are fixed (Bemporad and Morari, 1999). In our case the binary vector γ is empty, as no additional Boolean variables are needed to describe the hybrid dynamics of the DISC engine².

4 Controller Design

We describe how receding horizon optimal control for hybrid systems (Bemporad and Morari, 1999; Bemporad *et al.*, 2000) can

¹A more elaborate approach (not pursued here) wherein K is represented as a piecewise affine function of the intake manifold pressure that approximates the orifice equation, can also be handled with our design approach.

²Note that the MLD model (9) for the DISC engine can be rewritten as a Piecewise Affine (PWA) system: $x(t+1) = A_i x(t) + b_i u(t) + f_i$ if $K_i x(t) + H_i u(t) \leq W_i$ $i = 1, 2$, where $i = 1$ if $\rho = 0$, and $i = 2$ if $\rho = 1$. This confirms the equivalence between MLD and PWA system formally proved in (Bemporad *et al.*, 2000).

be usefully employed here to design a control law for the posed DISC engine control problem. The main idea is to setup a finite-horizon optimal control problem for the hybrid MLD system (9) by optimizing a performance index under operating constraints:

$$\min_{\xi} J(\xi, x(t)) \triangleq \sum_{k=0}^{N-1} \|Qy_k\|_1 + \|Ru_k\|_1, \quad (10a)$$

$$\text{subj. to } \begin{cases} x_0 &= x(t) \\ x_{k+1} &= Ax_k + B_1u_k + B_2\gamma_k + B_3z_k \\ y_k &= Cx_k + D_1u_k + D_2\gamma_k + D_3z_k \\ E_2\gamma_k + E_3z_k &\leq E_1u_k + E_4x_k + E_5, \end{cases} \quad (10b)$$

where $x(t)$ is the state of the MLD system at time t , $\xi \triangleq [u'_0, \gamma'_0, z'_0, \dots, u'_{N-1}, \gamma'_{N-1}, z'_{N-1}]'$ is the optimization vector, Q and R are weighting matrices, and $\|\cdot\|_1$ is the standard 1-norm. In our case,

$$\|Qy_k\|_1 = |q_1(p_{m,k} - p_{m,ref})| + |q_2(\tau_k - \tau_{ref})| + |q_3(\lambda_k - \lambda_{ref})| + |q_4\varepsilon_{\tau,k}| + |q_5\varepsilon_{\lambda,k}|, \quad (11a)$$

$$\|Ru_k\|_1 = |r_1(W_{th,k} - W_{th,ref})| + |r_2(W_{f,k} - W_{f,ref})| + |r_3(\delta_k - \delta_{ref})| + |r_4s_k| + |r_5(\rho_k - \rho(t-1))| \quad (11b)$$

and

$$\xi = [W_{th,0}, W_{f,0}, \delta_0, s_0, \rho_0, \dots, W_{th,N-1}, W_{f,N-1}, \delta_{N-1}, s_{N-1}, \rho_{N-1}]'.$$

The last term in (11b) is a penalty on the switch of combustion regime and is useful to avoid possible chattering of ρ at those time steps where both the stratified and homogeneous combustion regimes provide similar values of the performance function.

In (10) we assume that possible physical and/or logical constraints on the variables of the hybrid system are already included in the mixed-integer linear constraints of the MLD model, as they can be conveniently modeled through the language HYSDEL. Receding horizon control (RHC) amounts to repeatedly computing the optimal solution to (10) at each time t , and applying only the first optimal control move u_0^* as the input $u(t)$ to the system. Since the torque τ_k may not be measured in a vehicle,

Problem (10) can be translated into a mixed integer linear program (MILP), i.e., into the minimization of a linear cost function subject to linear constraints, where some of the variables are constrained to be binary, see (Bemporad *et al.*, 2000) for details.

The design of the controller is performed in two steps. First, the RHC controller based on the optimal control problem (10) is tuned in simulation using MILP solvers, until the desired performance is achieved. The RHC controller is not directly implementable, as it

would require an MILP to be solved on-line, which is clearly prohibitive on standard automotive control hardware. Therefore, for implementation, in the second phase the explicit piecewise affine form of the RHC law (see Section 6) is computed off-line by using the multi-parametric mixed integer programming solver presented in (Dua and Pistikopoulos, 2000). Although the resulting piecewise affine control action is *identical* to the RHC designed in the first phase, the on-line complexity is reduced to the simple evaluation of a piecewise affine function.

5 Simulations

We investigate the closed-loop behavior of the DISC engine under RHC control, by showing three different sets of simulations:

- (a) Hybrid MLD model (9) + RHC controller (nominal behavior)
- (b) Nonlinear model (1)–(4) + RHC controller (realistic behavior)
- (c) Nonlinear model (1)–(4) + RHC controller + additional noise on the engine torque τ (more realistic behavior).

We consider the control horizon $N = 4$ and two different sets of weights for the RHC controller:

$$\begin{aligned} q_1 = 1, & \quad q_2 = 700, & q_3 = 30, & \quad q_4 = 8 \times 10^3, & q_5 = 1 \\ r_1 = 10, & \quad r_2 = 0, & r_3 = 2, & \quad r_4 = 10^5, & r_5 = 10 \end{aligned}$$

for the *torque control mode*, where the main emphasis is on the engine brake torque τ following the demanded engine torque τ_d , and

$$\begin{aligned} q_1 = 1, & \quad q_2 = 10, & q_3 = 100, & \quad q_4 = 0, & q_5 = 100 \\ r_1 = 10, & \quad r_2 = 0, & r_3 = 10, & \quad r_4 = 10^5, & r_5 = 0.1 \end{aligned}$$

for the *air-to-fuel ratio control mode*, where the tracking of the air-to-fuel ratio becomes the most important aspect. Note that in torque control mode q_2 is selected much larger than q_1, q_3 , to emphasize the torque tracking performance, while in the air-to-fuel ratio control mode q_3 is selected much larger than q_1, q_2 , to emphasize the air-to-fuel ratio tracking performance. The weight r_4 penalizes the slack variable s that softens the constraints on λ and δ , and is very large in comparison with the other weights, so that constraints are enforced when this is possible ($s = 0$). The weight r_5 penalizes the switch of combustion regime. It has to be small in order to leave enough freedom in the choice of the best regime at each time step, although not too small in order to avoid possible chattering.

The closed-loop behavior of the MLD model under hybrid RHC control (nominal behavior) is reported in Figures 2–4. The simulation scenario involves a step in torque command³ accepted in torque control mode, followed by the transition between the stratified and

homogeneous combustion regimes in the torque control mode, and, finally, the activation of the air-to-fuel ratio control mode as may be needed for purging LNT. The nominal torque tracking performance is very good during the step acceptance and during the combustion regime switch; once the air-to-fuel ratio control mode is activated, however, the torque response starts following the intake manifold pressure response, since tracking the air-to-fuel ratio command now takes precedence. At the time of the combustion regime switch (as signified by ρ switching from 0 to 1) the fueling rate is decreased and the spark timing is aggressively retarded to maintain the torque output without violating the air-to-fuel ratio constraints of the homogeneous regime. Indeed, at the same intake manifold pressure conditions and if spark timing is at MBT, the homogeneous regime is actually more efficient than stratified so the torque would have a tendency to increase immediately after the switch unless the fueling rate is decreased or spark timing is retarded. Decreasing fueling rate may cause the air-to-fuel ratio to exceed its upper bound so aggressive spark retard is quite essential at the combustion regime switch point.

The RHC controller is then applied to the nonlinear model of the DISC engine and the resulting closed-loop response is shown in Figures 5–7. The transient torque tracking performance in the torque control mode has deteriorated somewhat given model mismatch, but the torque deviation from the reference is within the original specification of ± 2 Nm. The constraints on the ranges of the air-to-fuel ratio and spark timing are strictly enforced by the controller, see Figures 6,7.

Next, we added a random noise on the torque to mimic the feedback from real measurements or errors/noise in estimating torque. The resulting closed-loop response is shown in Figures 8–10.

The performance achieved by the RHC controller is comparable to that reported in (Kolmanovsky *et al.*, 2000), where a similar goal is achieved via nonlinear Lyapunov methods. The main benefit of the approach presented here is the natural ability of handling constraints and optimize a given performance criterion.

Each of the three sets of results discussed above was simulated in about 16 s on a PC Pentium III 650 MHz running Matlab/Simulink and the MILP solver of Cplex [15], that is about 80 ms per time step. Therefore, the controller is not directly suitable for implementation on automotive hardware, both for excessive CPU requirements and software complexity. This problem is dealt with in the next section.

6 Implementation as a Piecewise Affine Control Law

Once the tuning of the RHC controller is done in simulation, the explicit piecewise affine form of the control law can be computed off line by using a multiparametric mixed integer linear programming (mp-MILP) solver, according to the approach of (Bemporad *et al.*, 2000) [6]. Rather than solving the MILP (10) *on line* for the given current states and reference signals, the idea is to use the mp-MILP solver to compute *off line* the solution of the MILP (10) for all the

³We consider a somewhat more aggressive step than would normally take place in the actual vehicle, to evaluate the worst-case performance.

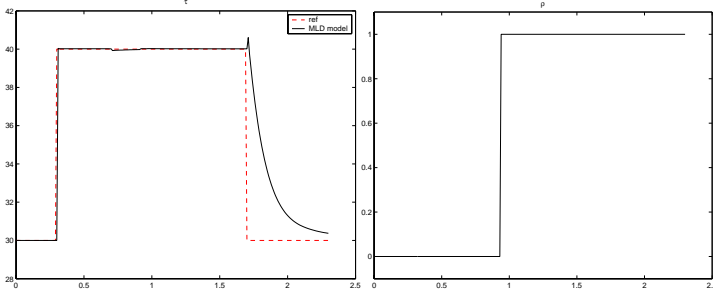

(a) Engine brake torque (dashed line: desired value, solid line: response of the MLD model)

(b) Regime of combustion

Figure 2. Nominal performance (MLD model + RHC controller)

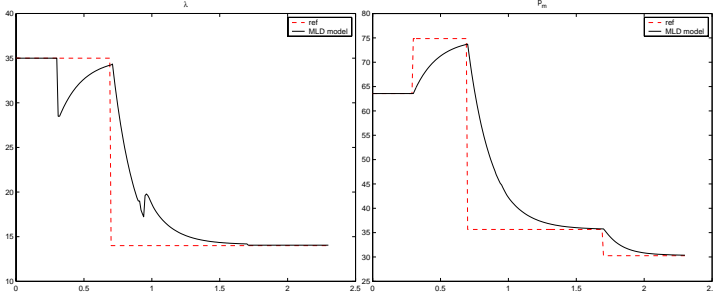

(a) Air-to-Fuel Ratio (dashed line: desired value, solid line: response of the MLD model)

(b) Intake Manifold Pressure (dashed line: desired value, solid line: response of the MLD model)

Figure 3. Nominal performance (MLD model + RHC controller)

states and reference signals within an (overestimate of the) expected range of values.

As shown in (Bemporad *et al.*, 2000), the control law has the piecewise affine form

$$u(t) = F_i \theta(t) + g_i \quad \text{if} \quad H_i \theta(t) \leq k_i, \quad i = 1, \dots, n_r, \quad (12)$$

where for the DISC model $u = [W_{ih} \ W_f \ \delta \ \rho]'$, and the set of parameters $\theta = [p_m \ \lambda \ \tau \ \varepsilon_\tau \ \varepsilon_\lambda \ p_{m,\text{ref}} \ \tau_{\text{ref}} \ \lambda_{\text{ref}} \ W_{ih,\text{ref}} \ W_{f,\text{ref}} \ \delta_{\text{ref}} \ \rho(t-1)]'$. Therefore, the sets of states + references is partitioned into n_r polyhedral cells, and an affine control law is defined in each one of them.

We remark that for any given $\theta(t)$ the on-line solution of RHC via MILP and the explicit off-line solution (12) provide the same result. Therefore, a good design strategy consists of tuning the RHC controller using simulation and on-line optimization, and then to convert the controller to its piecewise affine explicit form. The explicit controller will behave in exactly the same way at a much lower

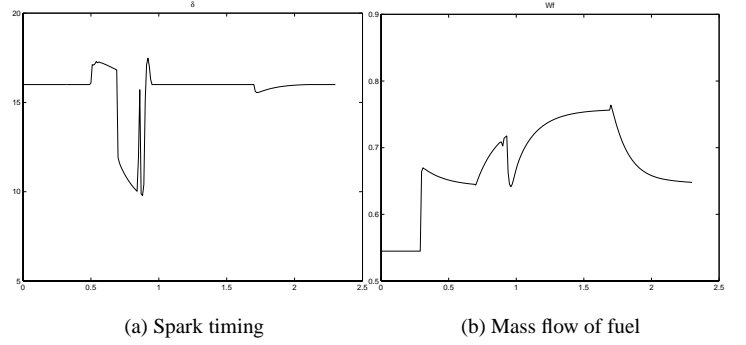
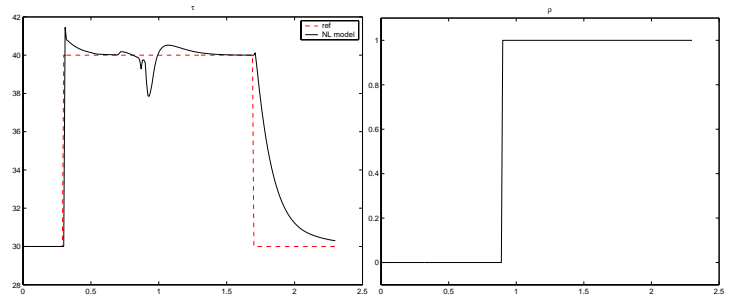

Figure 4. Nominal performance (MLD model + RHC controller)



(a) Engine brake torque (dashed line: desired value, solid line: response of the nonlinear model)

(b) Regime of combustion

Figure 5. Nonlinear model + RHC controller

computation cost. The control law can in fact be implemented on-line in the following simple way: (1) determine the i -th region that contains the current vector $\theta(t)$; (2) compute $u(t) = F_i \theta(t) + g_i$ according to the corresponding i -th control law. More efficient ways of evaluating piecewise affine control laws, based on the organization of the controller gains on a balanced search tree, are reported in (Tøndel *et al.*, 2002).

7 Conclusions

In this paper we have described a hybrid model and a receding horizon hybrid optimal control strategy for the DISC engine control problem. The key features of the approach is the simultaneous manipulation of discrete and continuous control variables within a receding horizon optimal control framework. We have shown that the transient response of the engine can be shaped as desired and constraints imposed by the engine feasible operating range can be enforced. Good performance has been demonstrated in simulation on a nonlinear model of a DISC engine and for a representative of

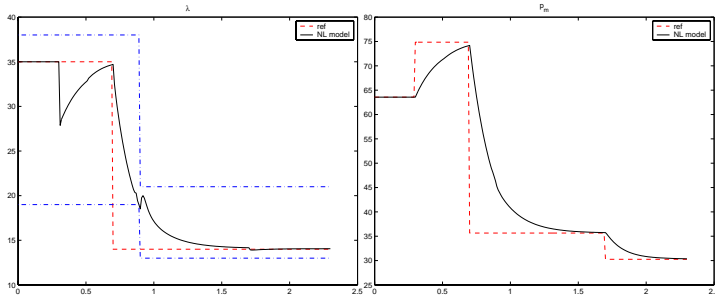

(a) Air-to-Fuel Ratio (dashed line: desired value, solid line: response of the nonlinear model, dash-dotted lines: constraints)
 (b) Intake Manifold Pressure (dashed line: desired value, solid line: response of the nonlinear model)

Figure 6. Nonlinear model + RHC controller

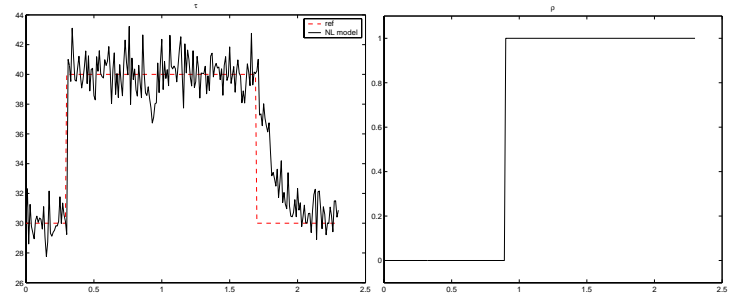

(a) Engine brake torque (dashed line: desired value, solid line: response of the nonlinear model)
 (b) Regime of combustion

Figure 8. Nonlinear model + RHC controller + noise on torque measurements

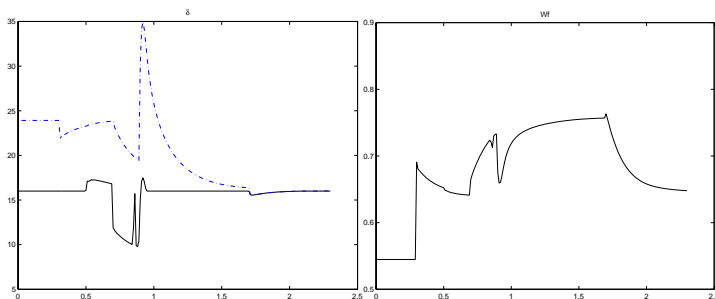

(a) Spark timing (solid line: actual value, dashed line: upper constraint (lower constraint is zero))
 (b) Mass flow of fuel

Figure 7. Nonlinear model + RHC controller

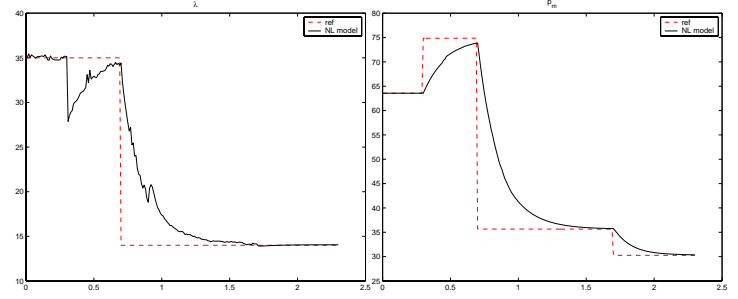

(a) Air-to-Fuel Ratio (dashed line: desired value, solid line: response of the nonlinear model)
 (b) Intake Manifold Pressure (dashed line: desired value, solid line: response of the nonlinear model)

Figure 9. Nonlinear model + RHC controller + noise on torque measurements

a real engine set of parameters. Furthermore, the resulting optimal controller can be obtained as an explicit piecewise affine function which is suitable for implementation on standard automotive control hardware. The experimental validation of the controller will be undertaken in a future work.

REFERENCES

- P.J. Antsaklis. A brief introduction to the theory and applications of hybrid systems. *Proc. IEEE, Special Issue on Hybrid Systems: Theory and Applications*, 88(7):879–886, July 2000.
- A. Balluchi, L. Benvenuti, M. Di Benedetto, C. Pinello, and A. Sangiovanni-Vincentelli. Automotive engine control and hybrid systems: Challenges and opportunities. *Proc. IEEE*, 88(7):888–912, 2000.
- A. Bemporad, F. Borrelli, and M. Morari. Piecewise linear optimal

controllers for hybrid systems. In *Proc. American Contr. Conf.*, pages 1190–1194, Chicago, IL, June 2000.

A. Bemporad, G. Ferrari-Trecate, and M. Morari. Observability and controllability of piecewise affine and hybrid systems. *IEEE Trans. Automatic Control*, 45(10):1864–1876, 2000.

A. Bemporad and M. Morari. Control of systems integrating logic, dynamics, and constraints. *Automatica*, 35(3):407–427, March 1999.

A. Bemporad, M. Morari, V. Dua, and E.N. Pistikopoulos. The explicit linear quadratic regulator for constrained systems. *Automatica*, 38(1):3–20, 2002.

A. Bemporad, F.D. Torrisi, and M. Morari. Discrete-time hybrid modeling and verification of the batch evaporator process benchmark. *European Journal of Control*, 7(4):382–399, July 2001.

F. Borrelli, A. Bemporad, M. Fodor, and D. Hrovat. A hybrid

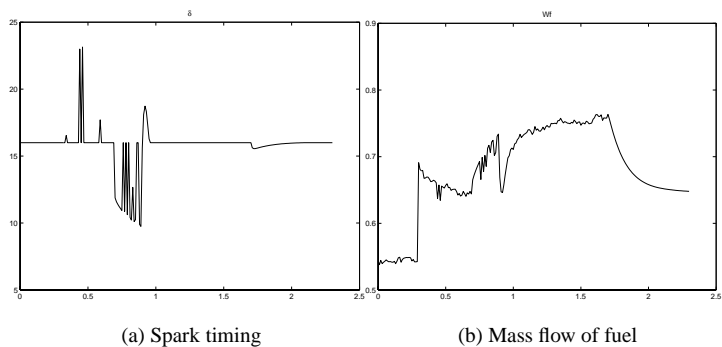

Figure 10. Nonlinear model + RHC controller + noise on torque measurements

1996.

J. Lygeros, C. Tomlin, and S. Sastry. Controllers for reachability specifications for hybrid systems. *Automatica*, 35(3):349–370, 1999.

C.C. Pantelides, M.P. Avraam, and N. Shah. Optimization of hybrid dynamic processes. In *Proc. American Contr. Conf.*, 2000. Available upon request from the authors.

P. Tøndel, T.A. Johansen, and A. Bemporad. Computation and approximation of piecewise affine control via binary search tree. In *IEEE Conf. on Decision and Control*, 2002. submitted.

F.D. Torrisi, A. Bemporad, and D. Mignone. HYSDEL - A language for describing hybrid systems. Technical Report AUT00-03, ETH Zurich, 2000. <http://control.ethz.ch/~hybrid/hysdel>.

approach to traction control. In *Hybrid Systems: Computation and Control*, Lecture Notes in Computer Science. Springer Verlag, 2001.

M.S. Branicky. *Studies in hybrid systems: modeling, analysis, and control*. PhD thesis, LIDS-TH 2304, Massachusetts Institute of Technology, Cambridge, MA, 1995.

M.S. Branicky and S.K. Mitter. Algorithms for optimal hybrid control. In *Proc. 34th IEEE Conf. on Decision and Control*, New Orleans, USA, December 1995.

V. Dua and E.N. Pistikopoulos. An algorithm for the solution of multiparametric mixed integer linear programming problems. *Annals of Operations Research*, pages 123–139, 2000.

K. Gokbayrak and C.G. Cassandras. A hierarchical decomposition method for optimal control of hybrid systems. In *Proc. 38th IEEE Conf. on Decision and Control*, pages 1816–1821, Phoenix, AZ, December 1999.

S. Hedlund and A. Rantzer. Optimal control of hybrid systems. In *Proc. 38th IEEE Conf. on Decision and Control*, pages 3972–3976, Phoenix, AZ, December 1999.

W.P.M.H. Heemels, B. De Schutter, and A. Bemporad. Equivalence of hybrid dynamical models. *Automatica*, 37(7):1085–1091, July 2001.

ILOG, Inc. *CPLEX 7.0 User Manual*. Gentilly Cedex, France, 2000.

J. Sun, I.V. Kolmanovsky, D. Brehob, J. Cook, J. Buckland, and M. Haghgooie. Modelling and control problems for gasoline direct injection engines. In *Proc. 1999 IEEE Conf. Control Applications*, pages 471–477, Hawaii, 1999.

I.V. Kolmanovsky, M.V. Druzhinina, and J. Sun. Nonlinear torque and air-to-fuel ratio controller for direct injection stratified charge gasoline engines. In *Proceedings of AVEC 2000, 5-th International Symposium on Advanced Vehicle Control*, Ann Arbor, Michigan, August 2000.

G. Labinaz, M.M. Bayoumi, and K. Rudie. A survey of modeling and control of hybrid systems. In *13th IFAC World Congress 1996*,